

242 C.C. BRITISH ANZANI TWIN TWO STROKE

ROTARY VALVE ENGINE UNIT.

(52 7/8" BORE X 57 1/4" STROKE.)

GEAR RATIOS.

ENGINE TO CLUTCH - 2.08/1

**GEARBOX:- 1, 1.35, 1.82
AND 2.93 TO 1.**

**FINAL DRIVE. 17T SPROCKET
FOR RENOLD 110046 CHAIN.**

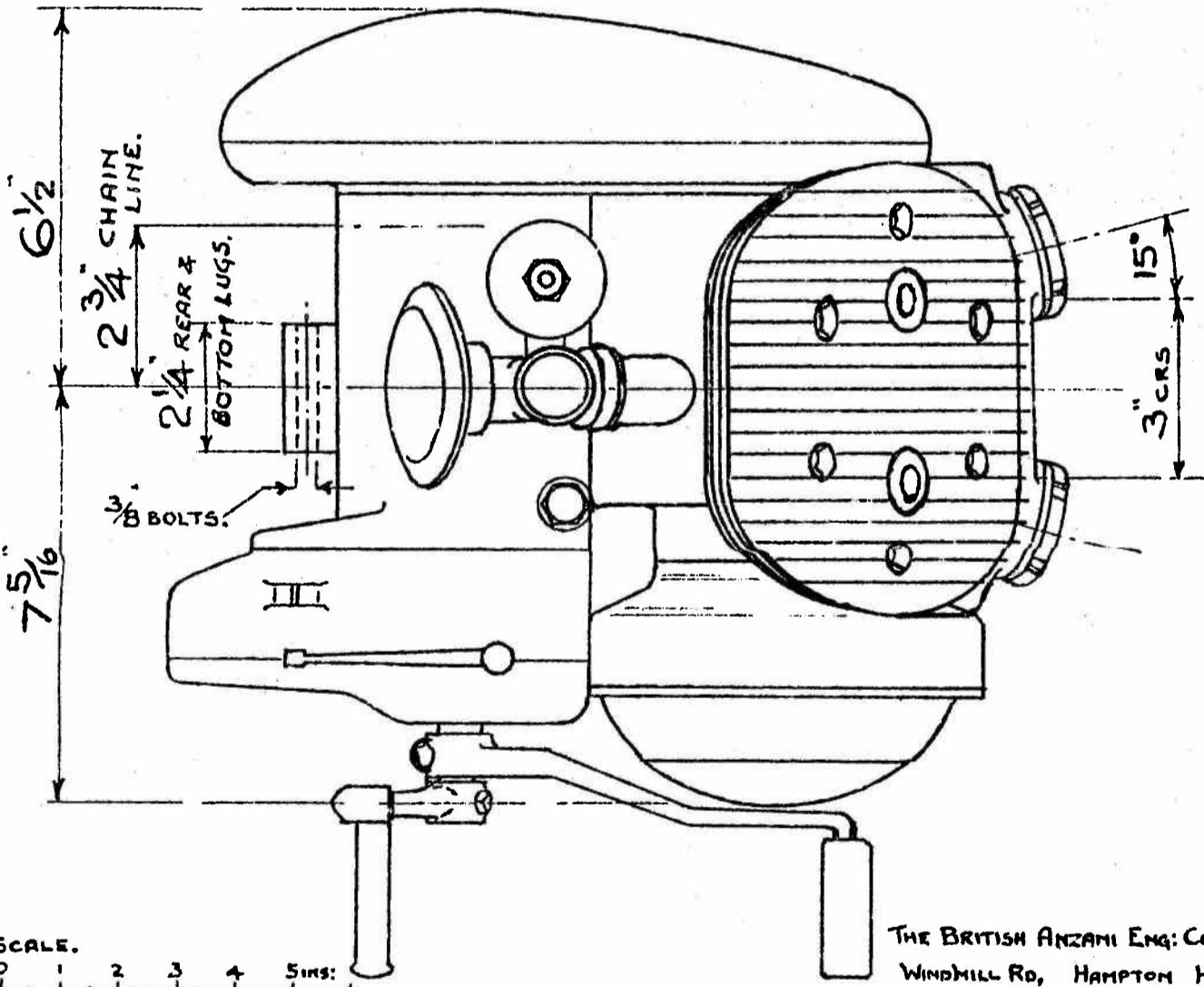
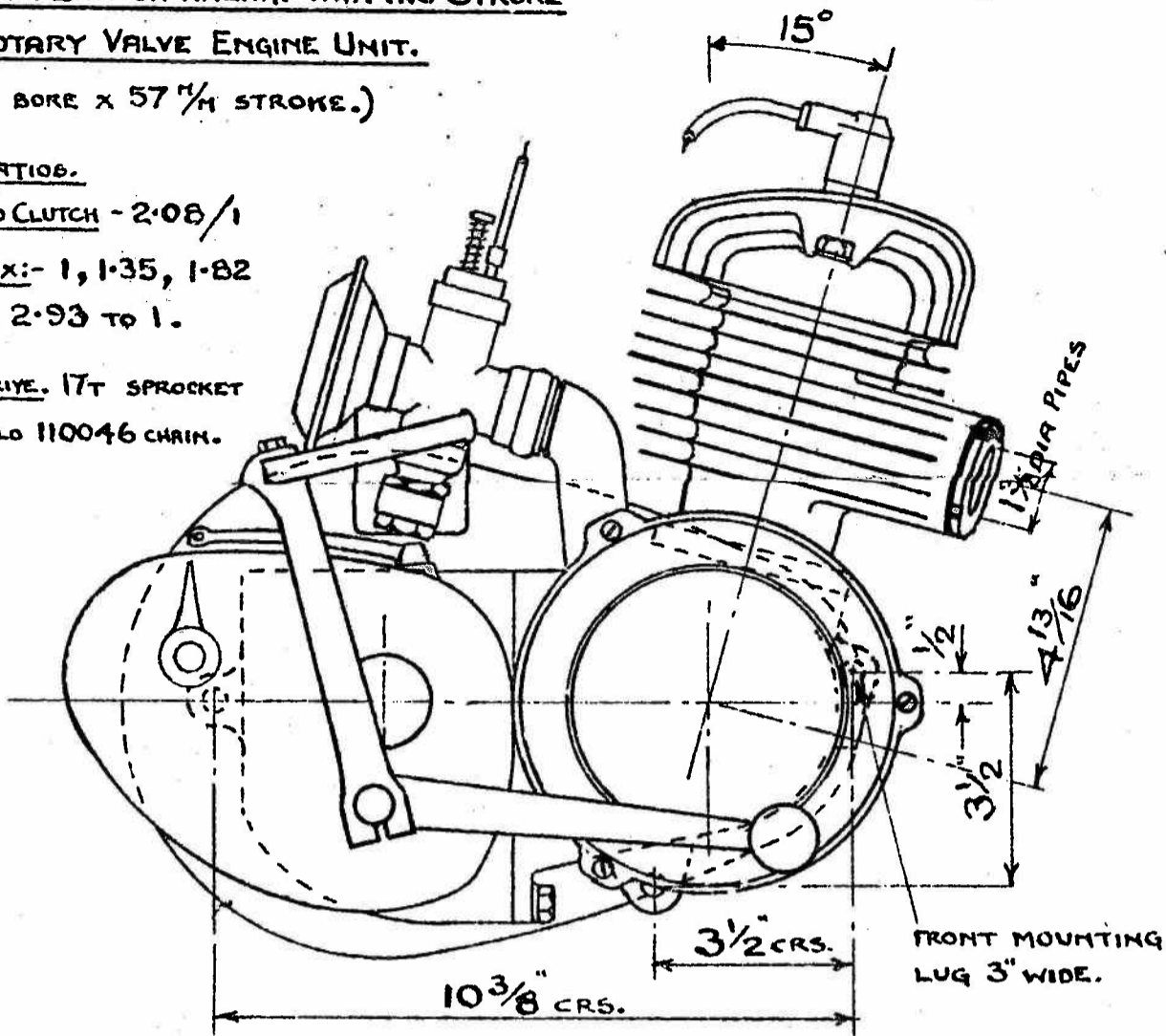

THE BRITISH ANZANI ENG. CO. LTD.
WINDMILL RD, HAMPTON HILL,
MIDDX.

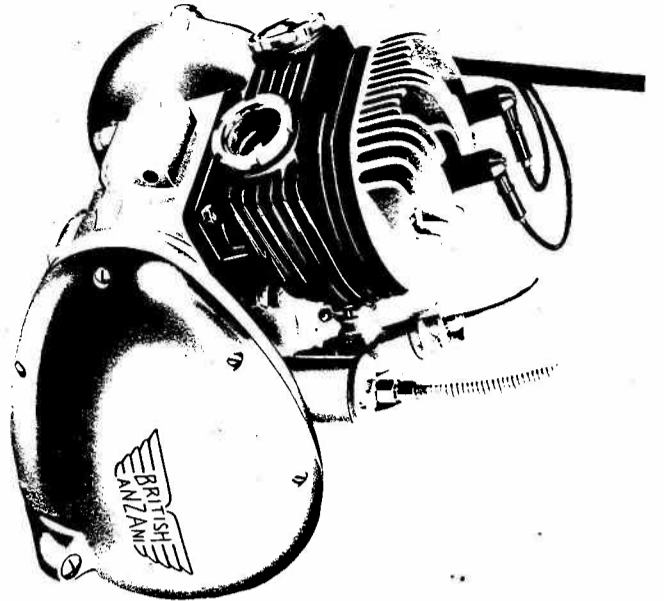

BRITISH ANZANI ROTARY VALVE, TWIN TWO STROKE
MOTOR CYCLE ENGINE GEAR UNIT.

Bore 52 m.m., Stroke 57 m.m., Capacity 242 c.c.
Alternate firing 180 degrees.
Twin transfer ports to each cylinder.
Built up crankshaft. Caged rollers to big ends.
Wico Pacy Magneto Generator for ignition and lighting.
Engine Clutch ratio 26 to 54, 3/4" pitch duplex primary chain.
Ratios of four speed Gearbox: 1, 1.35, 1.82 and 2.93 to 1.
Final drive sprocket 17 teeth.
Weight approx. 78 lbs.